

Original Instruction Manual
Auto Chain Grinder Model 730-120

OregonProducts.com



Table of Contents

1	Introduction	3	5	Operation	24
1.1	Important user information	3	5.1	Safety during operation	24
1.2	About this manual	3	5.2	Preparing for operation	24
1.3	Intended use	3	5.2.1	Preparing the grinding wheel	24
1.4	Nameplate	4	5.2.2	Setting the head-tilt angle	25
1.5	Recycling information	4	5.2.3	Setting the top-plate angle	26
			5.2.4	Inserting the chain	26
			5.2.5	Making the grinding settings	29
2	Safety	5	5.3	Operating the machine	31
2.1	Explanation of warning levels	5	5.4	Depth gauge grinding	32
2.2	General machine safety warnings	5			
2.3	Signs and symbols	7	6	Maintenance and Service	35
3	Product Description	8	6.1	Safety during maintenance	35
3.1	Product overview	8	6.2	Frequency of maintenance	35
3.2	Front view	9	6.3	Changing the grinding wheel and fitting the grinding wheel guard	36
3.3	Back view	10	6.4	Fastening the chain vise	37
3.4	Grinding head	11	6.5	Checking and adjusting the wire	37
3.5	Pneumatic chain tensioner	12	6.6	Service	38
3.6	Controls	13			
3.6.1	Grinding speed knob	14	7	Troubleshooting	39
3.7	Chain overview	14	7.1	Troubleshooting procedure	39
3.8	Technical data	15	7.2	Sharpening test	39
			7.3	Changing the pitch	39
			7.4	Issues	40
			7.5	Troubleshooting indicators	41
4	Installation	16			
4.1	Safety during installation	16	8	Accessories and Spare Parts	42
4.2	Site requirements	16	8.1	Ordering information	42
4.3	Unpacking the machine	16	8.2	List of accessories	43
4.4	Assembling the stand	17	8.3	Spare parts	44
4.5	Assembling the pneumatic chain tensioner	19			
4.6	Bench-mounting the machine	21	9	Instrumental Measurements	48
4.7	Installing the grinding wheel	22			
4.8	Test the machine before first use	23	10	Warranty and Service	49

1 Introduction

1.1 Important user information

⚠ WARNING Before you install, operate or perform maintenance on the machine, you must read the safety information in this manual. Obey the instructions in this manual to prevent injuries or damage to the equipment.

1.2 About this manual

This user manual describes how to safely install, operate, and perform basic maintenance on the Oregon 730-120 Auto Chain Grinder chain sharpening machine. This manual also describes the parts of the machine, and it shows different accessories and spare parts that are available.

1.3 Intended use

The machine must only be used to sharpen the cutting chains used on power saws, forestry machines and harvesters. It automatically sharpens the cutting teeth, and depth gauges on chains. The machine is designed for indoor use only.

Unintended use

The machine must not be used outdoors or in a manner that is not described in this manual.

1.4 Nameplate

This nameplate is placed on the Oregon 730-120 Auto Chain Grinder's grinding head.



1.5 Recycling information







This symbol shows that electrical and electronic equipment must not be disposed of as unsorted municipal waste. It must be collected separately. Recycle according to current local rules and regulations.













2 Safety

2.1 Explanation of warning levels

This section contains safety information for the Oregon 730-130 Auto Chain Grinder. This manual contains WARNINGS, CAUTIONS, and NOTES that are applicable for the safe operation of the machine.

-  **DANGER** Indicates a hazard with a high level of risk which, if not avoided, will result in death or serious injury.
-  **WARNING** Indicates a hazard with a medium level of risk which, if not avoided, could result in death or serious injury.
-  **CAUTION** Indicates a hazard with a low level of risk which, if not avoided, could result in minor or moderate injury.
-  **IMPORTANT** Indicates a potential situation exists which, if not avoided, may result in damage to your grinder or property.

2.2 General machine safety warnings







-  **WARNING** Read all safety warnings, instructions, illustrations, and specifications provided with this machine. Failure to follow all instructions listed below may result in electric shock, fire, and/or serious injury. Save all warnings and instructions for future reference.
-  **WARNING** Keep work area clean and well lit. Cluttered or dark areas invite accidents.
-  **WARNING** Do not operate machines in explosive atmospheres, such as in the presence of flammable liquids, gases, or dust. Machines create sparks which may ignite the dust or fumes.
-  **WARNING** Keep children and bystanders away while operating a machine. Distractions can cause you to lose control.
-  **WARNING** Machine plugs must match the outlet. Never modify the plug in any way. Do not use any adapter plugs with earthed (grounded) machines. Unmodified plugs and matching outlets will reduce risk of electric shock.
-  **WARNING** Avoid body contact with grounded surfaces, such as pipes, radiators, ranges, and refrigerators. There is an increased risk of electric shock if your body is earthed or grounded.
-  **WARNING** Do not expose machines to rain or wet conditions. Water entering a machine will increase the risk of electric shock.
-  **WARNING** Do not abuse the cord. Never use the cord for carrying, pulling, or unplugging the machine. Keep cord away from heat, oil, sharp edges, or moving parts. Damaged or entangled cords increase the risk of electric shock.
-  **WARNING** If operating a machine in a damp location is unavoidable, use a residual current device (RCD) protected supply. Use of an RCD reduces the risk of electric shock.
-  **WARNING** Stay alert, watch what you are doing, and use common sense when operating a machine. Do not use a machine while you are tired or under the influence of drugs, alcohol, or medication. A moment of inattention while operating machines may result in serious personal injury.
-  **WARNING** Use personal protective equipment. Always wear eye protection. Protective equipment such as a dust mask, non-skid safety shoes, hard hat, or hearing protection used for appropriate conditions will reduce personal injuries.
-  **WARNING** Prevent unintentional starting. Ensure the switch is in the off-position before connecting to power source and/or battery pack, picking up, or carrying the machine. Carrying machines with your fingers on the switch or energizing machines that have the switch on invites accidents.
-  **WARNING** Remove any adjusting key or wrench before turning the machine on. A wrench or a key left attached to a rotating part of the machine may result in personal injury.

- ⚠ WARNING** Do not overreach. Keep proper footing and balance at all times. This enables better control of the machine in unexpected situations.
- ⚠ WARNING** Dress properly. Do not wear loose clothing or jewelry. Keep your hair and clothing away from moving parts. Loose cloths, jewelry, or long hair can be caught in moving parts.
- ⚠ WARNING** If devices are provided for the connection of dust extraction and collection facilities, ensure these are connected and properly used. Use of dust collection can reduce dust-related hazards.
- ⚠ WARNING** Do not let familiarity gained from frequent use of tools allow you to become complacent and ignore tool safety principles. A careless action can cause severe injury within a fraction of a second.
- ⚠ WARNING** Do not force the machine. Use the correct machine for your application. The correct machine will do the job better and safer at the rate for which it was designed.
- ⚠ WARNING** Do not use the machine if the switch does not turn it on and off. Any machine that cannot be controlled with the switch is dangerous and must be repaired.
- ⚠ WARNING** Disconnect the plug from the power source and/or remove the battery pack, if detachable, from the machine before making any adjustments, changing accessories, or storing machines. Such preventive safety measures reduce the risk of starting the machine accidentally.
- ⚠ WARNING** Store idle machines out of the reach of children and do not allow persons unfamiliar with the machine or these instructions to operate the machine. Machines are dangerous in the hands of untrained users.
- ⚠ WARNING** Maintain machines and accessories. Check for misalignment or binding of moving parts, breakage of parts and other condition that may affect the machine's operation. If damaged, have the machine repaired before use. Many accidents are caused by poorly maintained machines.
- ⚠ WARNING** Keep cutting tools sharp and clean. Properly maintained cutting tools with sharp cutting edges are less likely to bind and easier to control.
- ⚠ WARNING** Use the machine, accessories, and tool bits etc. in accordance with these instructions, taking into account the working conditions and the work to be performed. Use of the machine for operations different from those intended could result in hazardous situation.
- ⚠ WARNING** Keep handles and grasping surfaces dry, clean, and free from oil and grease. Slippery handles and grasping surfaces do not allow for safe handling and control of the machine in unexpected situations.
- ⚠ WARNING** Have your machine serviced by a qualified repair person using only identical replacement parts. This will ensure that the safety of the machine is maintained.
- ⚠ WARNING** Before you install, operate, or perform maintenance on the machine, you must read the safety information in this manual. Obey the instructions in this manual to prevent injuries or damage to the equipment.
- ⚠ WARNING** Put the machine in a dry indoor area with good lighting. Do not let the machine become wet or damp. Do not put the machine near gas, liquids, or other flammable materials.
- ⚠ WARNING** The user must only perform maintenance that is described in this manual. Only approved and trained service technicians can service the machine.
- ⚠ WARNING** To prevent mistakes when chains are sharpened, it is very important to understand how the Oregon 730-120 Auto Chain Grinder works. Read the instructions carefully before operating the machine.
- ⚠ WARNING** Always wear safety gloves, protective glasses, and any other personal protective equipment suitable for your task.
- ⚠ WARNING** Stop the machine immediately if it does not work correctly.

- ⚠ WARNING** Before a chain is sharpened, make sure that the grinding wheel is not cracked and does not vibrate or wobble. If the grinding wheel is damaged, it must be replaced immediately, see section 6.3, "Change the grinding wheel and fit the grinding wheel guard". You can also do a simple "ring test" to check for damage; see 4.7, "Installing and centering the grinding wheel." If abnormal vibrations occur during operation, immediately stop the machine and check the condition of the grinding wheel.
- ⚠ WARNING** Place the power converter where there is as little dust as possible and out of reach of sparks from the machine.
- ⚠ WARNING** Attach air hoses and cables with cable clamps to make sure no one trips over them.
- ⚠ CAUTION** Only use accessories that are supplied or approved by the manufacturer.
- ⚠ CAUTION** If the pitch is not correctly set, the chain will be pushed into an incorrect sharpening position. This may result in a damaged chain.
- ⚠ CAUTION** If the metal of a cutting link turns blue during grinding, the speed is set too high and the metal is overheated. This can cause the metal in the cutting tooth to lose its sharpness. Replace the damaged cutting link or sharpen the chain again.
- ⚠ CAUTION** Grinding dust can interfere with the machine's operation. Clean the machine daily to remove all of the grinding dust. Use a vacuum cleaner, brush, or similar to clean the machine.
- ⚠ CAUTION** Make sure that the floor where the machine is placed is flat and level. Attach the stand to the floor with screws.

2.3 Signs and symbols

See the table below for information about the signs and symbols on The Oregon 730-120 Auto Chain Grinder:

Sign/Symbol	Description
	Always wear protective glasses when using the machine.
	Always wear protective gloves when using the machine.
	Warning! A warning tells you about conditions that can cause injury or death if you do not obey the instructions. Discontinue use until all conditions are met.
	Before you install, operate, or perform maintenance on the machine, you must read the safety information in this user manual. Obey the instructions to prevent injuries or damage to the equipment. This machine complies with the applicable European directives.
	Risk for cutting injuries. Keep fingers away from the area when the machine is on.
	Risk for pinching injuries. Keep fingers away from the area when the machine is on.
	This product has been independently tested by Intertek and is found to be in compliance with UL62841-1 and Canadian Standards Association Std C22.2 #62841-1.

3 Product Description

3.1 Product overview

The Oregon 730-120 Auto Chain Grinder is a machine that sharpens chains. The machine can sharpen 3/4" pitch chains for power saws, forestry machines, and harvesters. A pneumatic chain tensioner is attached to the stand. It secures and tensions the chain when it is sharpened. The stand has 2 chain hangers which makes it easier to separate the sharpened chains from chains that are not yet sharpened. Accessories are available for extra long chains.

3.2 Front view

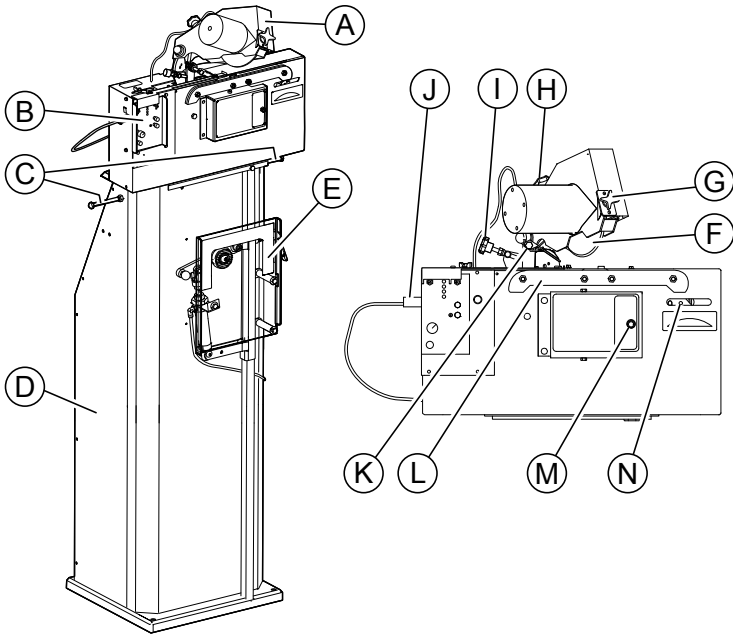

Pos	Part	Description
A	Grinding head	Holds the grinding wheel in its correct position.
B	Control panel	The controls starts and stops the different functions of the machine. See section 3.6, "Controls" for further information.
C	Chain hangers	Hangers on both sides for unsharpened or sharpened chains.
D	Stand	Holds the machine.
E	Tensioner	Secures the chain in the correct position.
F	Grinding wheel	The wheel that sharpens the chain.
G	Grinding wheel centering knob	Centers the grinding wheel above the chain.
H	Grinding depth knob	Sets the grinding depth for the gullets.
I	Chain pusher adjustment knob	Sets the grinding length.
J	Power supply cable	Supplies electricity to the machine.
K	Chain pusher	Advances the chain through the vise.
L	Chain vise	Positions the chain as it moves in the machine.
M	Left-right alignment screw	Sets the right and left cutters to equal length.
N	Top-plate angle screw	Sets the top-plate angle, 0-35°. Default 35°.

3.3 Back view

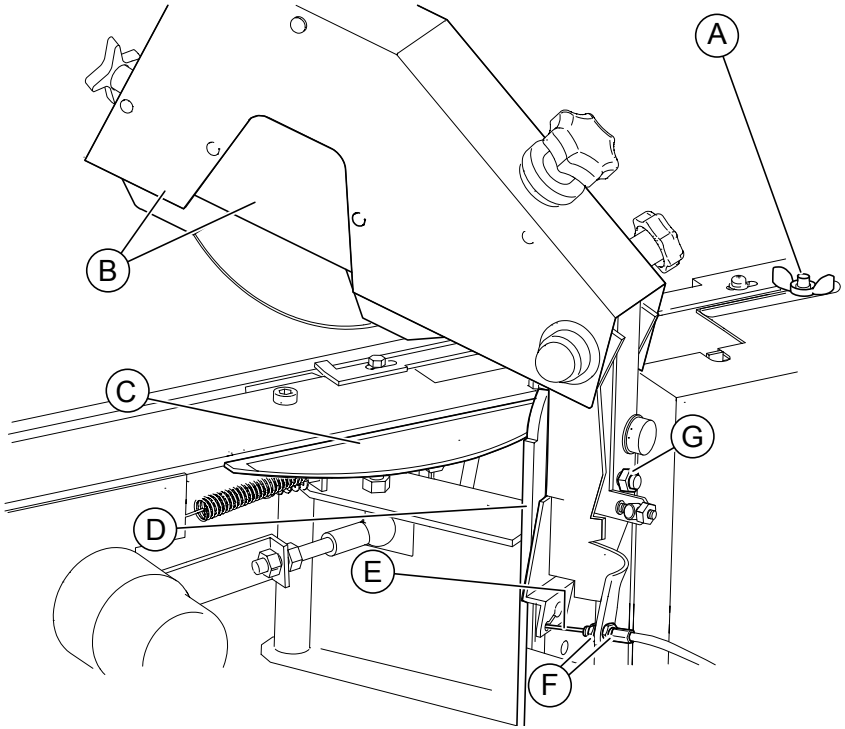

Pos	Part	Description
A	Pitch adjustment wing	Adjusts the pitch. Note! This wing is idle in the Oregon 730-120 machine.
B	Grinding head cover and grinding wheel guard	Protects the grinding head and grinding wheel; it also protects the user from sparks during grinding.
C	Top-plate angle scale	Shows the top-plate angle on a scale from 0-35°. Default: 30°. It is set using the top-plate angle screw (letter N on front view illustration on page 9).
D	Head-tilt angle scale	Shows the head-tilt angle on a scale from 50-90°. Default: 60°.
E	Wire	Controls the vertical movement of the grinding head.
F	Wire adjustment knobs	Adjusts the wire that controls the vertical movement of the grinding head.
G	Head-tilt angle nut	Sets the head-tilt angle on the head-tilt angle scale. (D)

3.4 Grinding head

The grinding wheel on the grinding head sharpens the chains. The type of wheel, the top-plate angles, the settings of the grinding head, and the profiling of the grinding wheel all determine how the chain is sharpened.

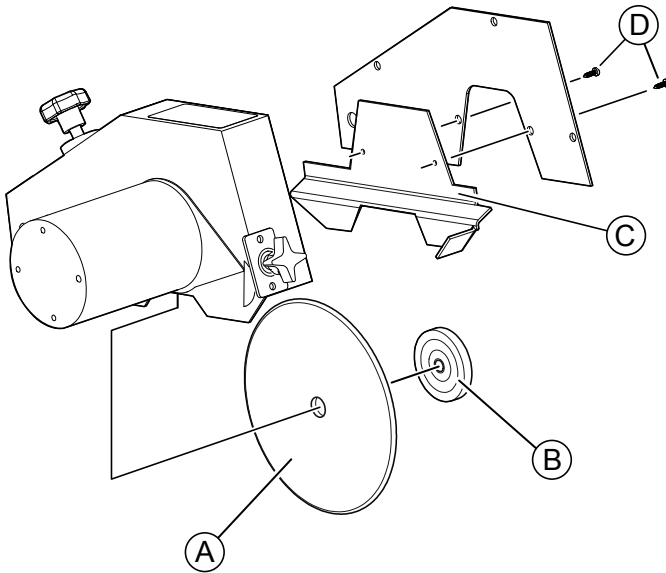

Pos	Part	Description
A	Grinding wheel	Grinds the chain.
B	Grinding wheel nut	Keeps the grinding wheel in place.
C	Grinding wheel guard	Protects the user and grinding wheel when the chain is sharpened.
D	2 screws	Secures the grinding wheel guard in place.

3.5 Pneumatic chain tensioner

The purpose of the pneumatic chain tensioner is to attach and secure the chain in the correct operating position. It also keeps the chain properly tensioned during grinding.

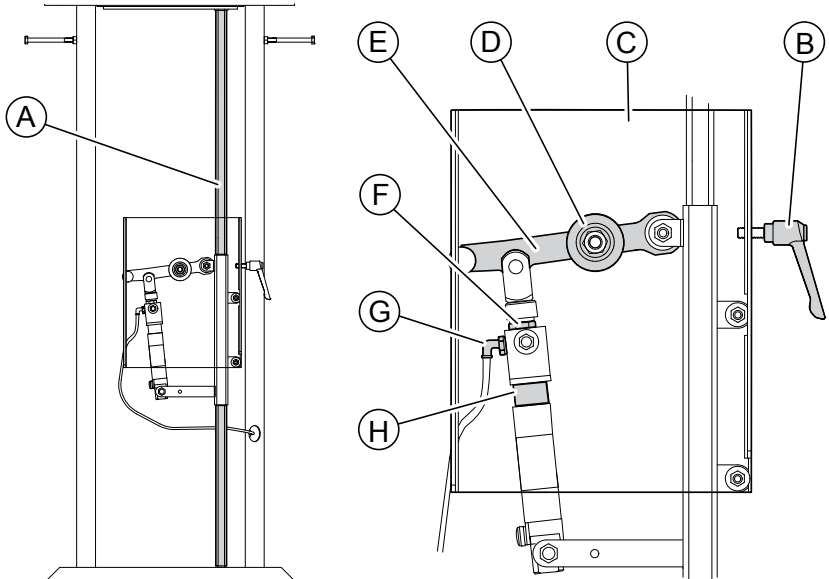

Pos	Part	Description
A	Tensioner rail	Where the tensioner slides up and down. The tensioner is moved to fit chains of different lengths.
B	Locking handle	Locks the tensioner in place.
C	Protection cover	Protects the user from pinch injuries.
D	Tensioner roll	Allows the chain to move when it is sharpened.
E	Tensioner arm/Quick release	Allows the user to tension or release the chain faster than if the locking handle is used (quick release function).
F	Pneumatic piston nut	Holds the pneumatic piston in place.
G	Air hose	Supplies the tensioner with pneumatic air.
H	Pneumatic piston.	Gives flexibility to the tensioner.

Note: You can also order a telescopic chain extension kit if you need to fit longer chains. See section 8, "Accessories and Spare Parts"

3.6 Controls

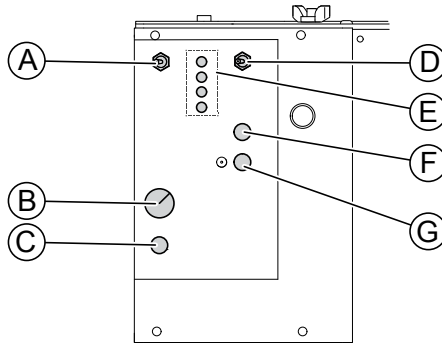

Pos	Part	Description
A	Chain pusher switch	ON: starts the chain feed, so that the chain moves in a forward direction. OFF: stops the chain feed.
B	Grinding speed knob	Sets the grinding speed.
C	Emergency stop button	Shuts off the power and stops the machine. The emergency stop button is used to turn off the machine after operation and to do an emergency shut-down.
D	Grinding wheel motor switch	Starts the grinding motor.
E	Indicators	Indicates potential problems with the machine. See section 7.5, "Troubleshooting indicators"
F	Grinding head positioning button	Changes the angle of the grinding head from left to right or vice versa.
G	Power button	Turns on the machine.

3.6.1 Grinding speed knob

The grinding speed knob sets the speed of the grinding wheel. The speed can be set to different speeds to grind 0" to 5/32" (0 to 4 mm) of the cutting teeth. At low speed, grinding is done in a pulsing motion.

3.7 Chain overview

This section describes the definitions for the parts of a normal chain.

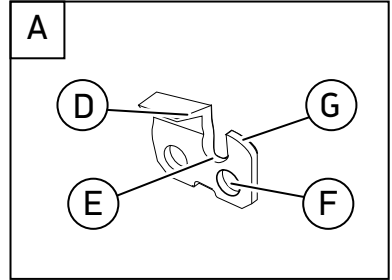
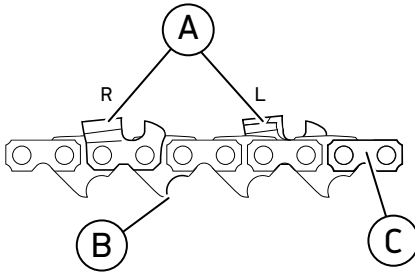

Pos	Part	Description
A	Cutters	R: Right cutter. L: Left cutter.
B	Drive link	The lower part of a link. Used to push the chain forward in the chainsaw, etc.
C	Tie strap	The links separating the cutters.
D	Cutting tooth	The part of the cutter that cuts chain.
E	Gullet	The space between the cutting tooth and the depth gauge.
F	Rivet hole	A hole where the rivet is placed.
G	Depth gauge	The front part of the cutter.

3.8 Technical data

Parameter	Value
Supply voltage	12-15 V DC
Power	144 W
Current	12 A
Over-current protection	Automatic fuse type ptc
Rotation speed	3250 rpm
Peripheral speed	25 m/s
Grinding wheel dimensions (for the grinding wheels included in the delivery)	Outer diameter (OD) × Width (W) × Inner diameter (ID): <ul style="list-style-type: none"> • 5 7/8" x 3/8" x 5/8" (150 mm x 10 mm x 16 mm) • 5 7/8" x 5/16" x 5/8" (150 mm x 7.9 mm x 16 mm)
Max dimensions for the Oregon 730-120 Auto Chain Grinder	Length (L) x Width (W) x Height (H): 18.9" x 12.9" x 20.4" (480 mm x 330 mm x 520 mm)
Dimensions, stand	Length (L) x Width (W) x Height (H): 13.5" x 14.1" x 42.1" (345 mm x 360 mm x 1070 mm)
Weight of the machine	37 lbs (16.9 kg)
Weight of the stand	72.8 lbs (33 kg)
Compressed air supply pressure	75 – 116 PSI

4 Installation

4.1 Safety during installation

⚠ WARNING Before you install, operate, or perform maintenance on the machine, you must read the safety information in this manual. Obey the instructions in this manual to prevent injuries or damage to the equipment.

⚠ WARNING Always wear safety gloves, protective glasses, and any other personal protective equipment suitable for your task.

4.2 Site requirements

⚠ WARNING Put the machine in a dry area indoors with good lighting. Do not let the machine become wet or damp. Do not put the machine near gas, liquids, or other flammable materials.

⚠ CAUTION Make sure that the floor where the machine is placed is flat and level. Attach the stand to the floor with screws.

Note: Machines can be set up on a bench or you can use the included stand. Please note that mounting hardware for the bench is not supplied with the machine.

4.3 Unpacking the machine

Note: For a video demonstration of how to unpack, assemble, install, and operate the machine, visit OregonProducts.com.

1. Unpack the crates.

Note: Keep the delivery crates and packing materials. Pack the machine in them if it is moved or sent for service. The crates and packing materials will minimize the risk of damage during transportation.

2. Make sure that all parts in the list below are included in the delivery:

- Oregon 730-120 Auto Chain Grinder machine
- stand (with set of screws, nuts and bolts, for assembly)
- pneumatic tensioner, air tubes, and 2 nipples for different types of compressors
- converter (with 2 screws for assembly)
- Oregon 730-120 Auto Chain Grinder User manual (this document)
- rectangular profile stone (55 x 15 x 15 mm) and profile template
- a chain pusher for depth gauge grinding
- hex key, which is used to change the top-plate angle
- Allen wrench, which is used for tightening
- grinding wheel guard (with 2 screws for assembly)
- 2 types of ceramic grinding wheels (OR600-38 and OR600-14)
- screws, nuts, and bolts for assembly

Note: For your convenience, you may also use your own tools to assist the machine's assembly.

3. Remove all packing materials. Remove the metal plate from the chain vise, which is used to protect the grinding head during transport. Remove the air hose connector's packing material.

4.4 Assembling the stand

⚠ CAUTION The Oregon 730-120 Auto Chain Grinder machine must always be safely attached to the stand when it is used with a stand. When you use a bench, securely attach the machine to the bench.

1. To mount the grinder on the stand, begin by assembling the stand.
2. The stand comes in 4 pieces: two sides, one base, and one front piece.

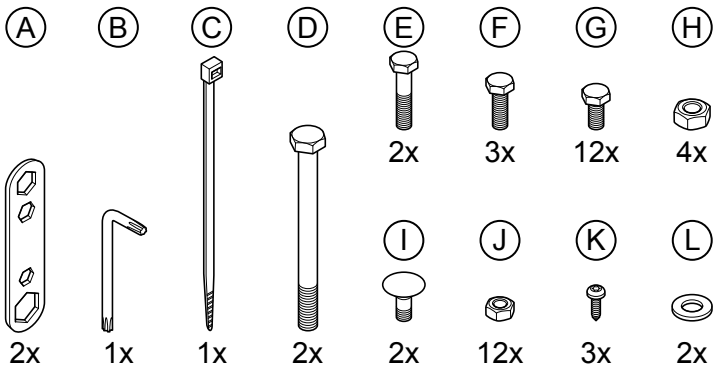
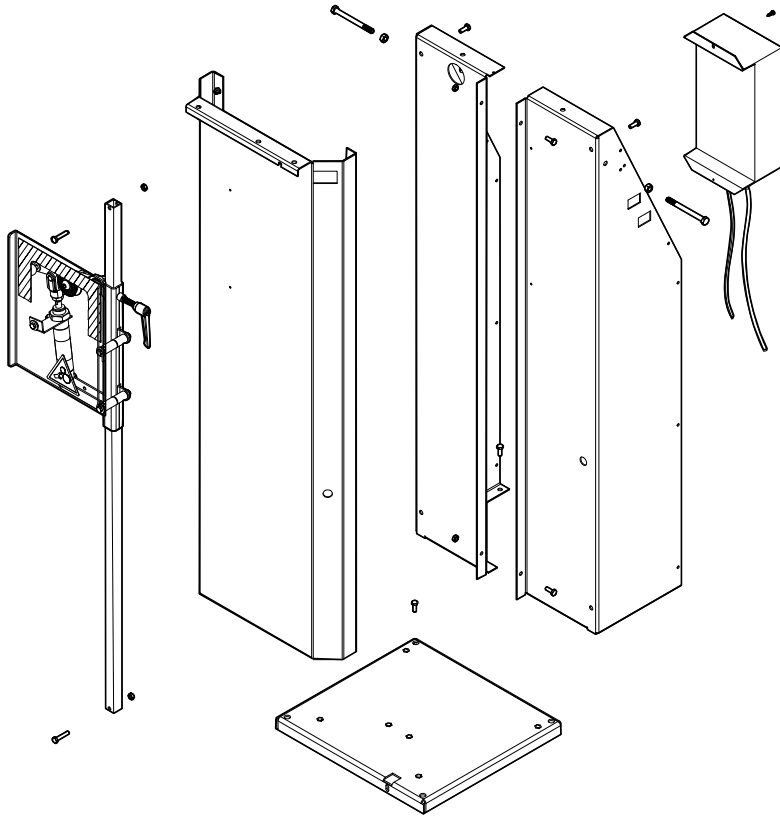

3. Start by placing the base piece on the floor. Place the front piece on top of the base piece by aligning the holes they have on the front right and left corners. Bolt the front piece to the base through the two holes using the provided wrench.

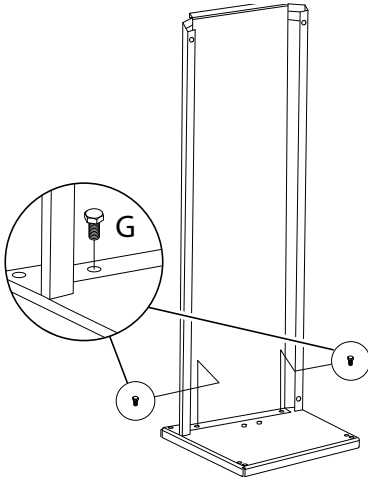

4. Next, attach the two side pieces to each other with provided bolts through the holes at the intersection of two pieces to create the side support piece.

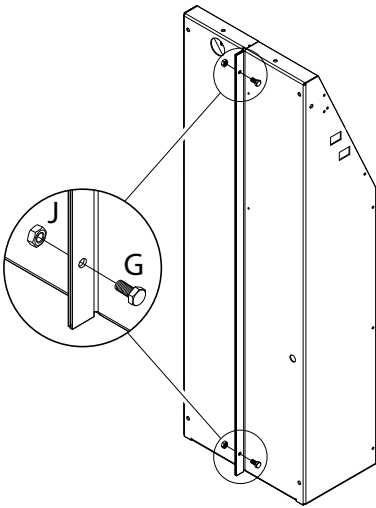

5. To complete the assembly of the stand, bolt the side support first to the base and then to the front piece.

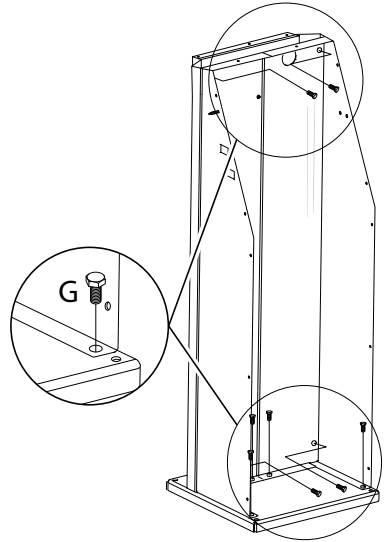

4.5 Assembling the pneumatic chain tensioner

To assemble the pneumatic chain tensioner, lay the stand on the floor with the front piece facing up.

1. First, attach the handle to the pneumatic chain tensioner.

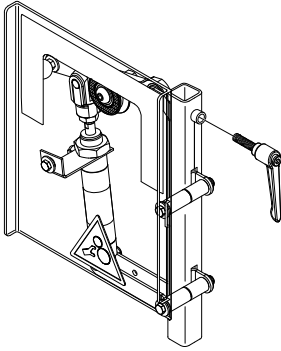

2. Then insert the rod through the unit and insert the bottom part of the rod onto the base of the stand.

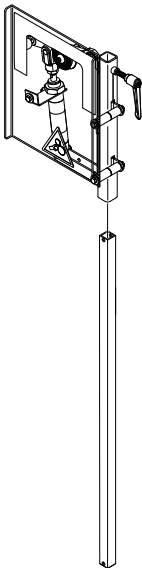

3. To secure the rod, start from the top. Place the provided nut on the top of the hole and insert the bolt from the bottom of the rod towards the top, and then through the nut.

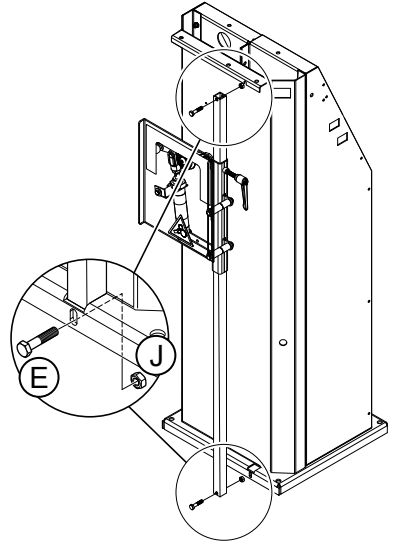

4. Do not completely tighten the bolt. Once the bolt is in place, slide it into the slot located at the top part of the stand, then tighten the bolt.
5. Once the top portion is secured, use the second set of nuts and bolts to fix the bottom part of the rod to the stand. After securing both the bottom and the top, bring the stand back to an upright position.

6. There are two air lines to be attached to the pneumatic chain tensioner: one with an air fitting unit attached to the end and one without a fitting.
7. Insert the line without the fitting through the hole located on the left side of the stand, bringing it from back to the front. Route the line through the back of the rod and insert it into the pneumatic tensioner until it sits in place.

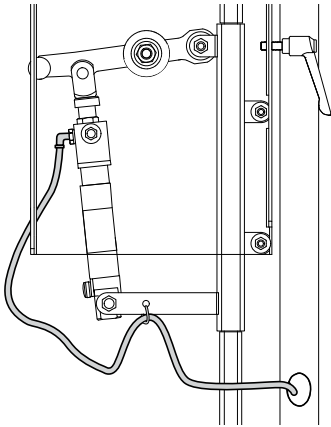

8. Now attach the chain holders that will allow you to keep loops of chain up off of the ground. Insert the provided long bolts into the holes located on both sides of the stand and fix them in place with a 0.5" (13 mm) wrench.

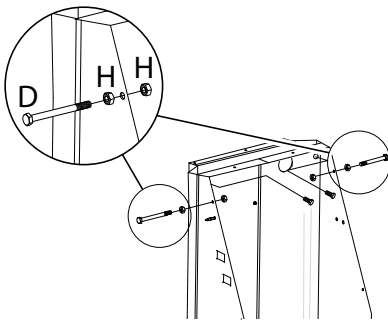

9. The stand will need to be secured on the floor through the holes located at the base of the stand.

10. After the stand is assembled and secured, bolt the AC/DC converter to the back of the stand by aligning the two holes located at the top and the bottom of the converter to the holes on the stand.

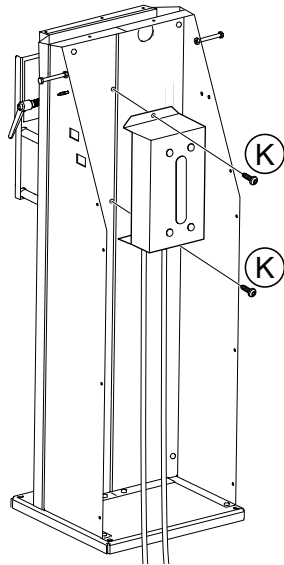

11. Next, place the machine on the stand. Fix it to the stand through the 3 holes located at the back of the machine with the bolts and nuts provided.

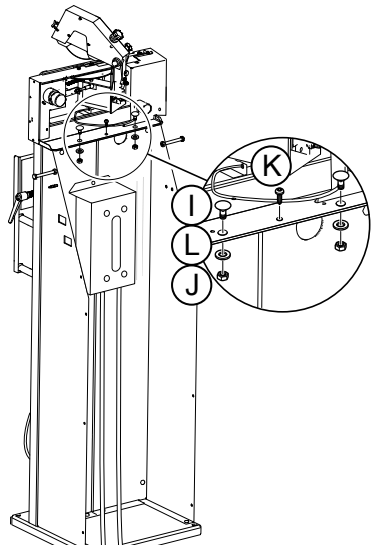

- To connect the AC/DC converter unit to the machine, plug in the black and red power cable into the control panel through the slot on the left hand side of the machine.

Note: For best performance, use the converter provided by Oregon.

⚠ WARNING Put the power converter where there is as little dust as possible and out of reach of sparks from the machine.

- To connect the air unit, slip the air line that has been attached to the pneumatic chain tensioner into the slot marked as "out" at the back of the machine. Then insert the second airline into the slot marked "in". Next, connect the line with the fitting unit to an air compressor with a minimum of 75 and maximum of 116 psi.

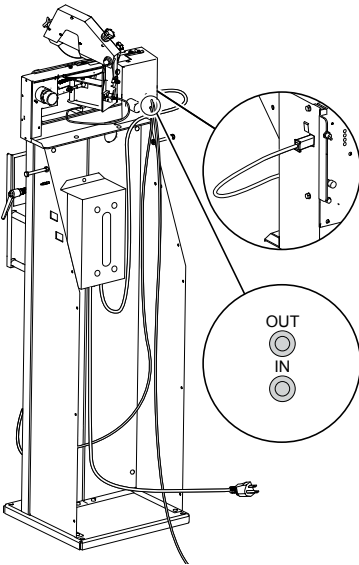

⚠ WARNING Attach air hoses and cables with cable clamps to make sure no one trips over them.

4.6 Bench-mounting the machine

- An alternative to having the grinder on a stand is to bench-mount the machine.

IMPORTANT: Although the 730-120 machine can be used on a bench with a chain weight, it is strongly recommended to use it with the stand and air tensioner for the best grinding results.

- Bench-mounting offers you flexibility and the ability to sharpen chain virtually anywhere using the electrical from any wall outlet or use of a 12V power source.

⚠ WARNING Put the power converter where there is as little dust as possible and out of reach of sparks from the machine.

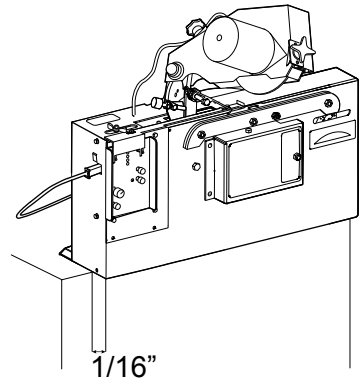

- If the machines are not being used with the stand and the pneumatic tensioner, it should be used with the weight tensioner in order to provide the chain with the tension needed for grinding. The weight tensioner is available separately for purchase. (See section 8, "Accessories and Spare Parts")

4.7 Installing the grinding wheel

Note: The first step in preparing the grinder for use is installing and centering the appropriate grinding wheel.

1. The grinder comes with two wheel sizes: 5/16" (7.9 mm) and 3/8" (10 mm). The wheels are 5 7/8" (150 mm) in diameter with 5/8" (16 mm) arbor size. It is critical to select the wheel of the appropriate thickness for each chain.
2. The correct wheel size for a particular Oregon saw chain can be found in several sources: this manual, the back of the Oregon chain packaging, Oregon Maintenance and Safety Manual, or online at OregonProducts.com.

⚠ WARNING Inspect the grinding wheel and make sure that it is not cracked or damaged. There is a simple test (called the "ring test") that you can do to check for damage to a grinding wheel. Hold the grinding wheel up by its center hole. Knock the edge of the grinding wheel gently with a non-metallic object (like the plastic handle of a screwdriver). If the grinding wheel makes a dull, non-metallic noise, then the wheel could be damaged. **DO NOT USE IT. CRACKED GRINDING WHEELS MUST BE REPLACED IMMEDIATELY.** See also, 6.3, "Changing the grinding wheel and fitting the grinding wheel guard"

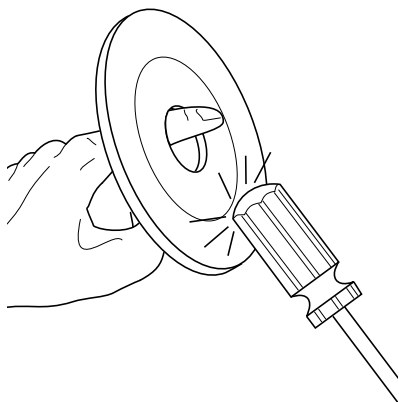

3. Once the grinding wheel has been verified, you're ready to begin the install.
4. Start by removing the grinding wheel shield (C) to access the wheel attachment nut (B). Use the provided Allen wrench to loosen the retaining screw (D).

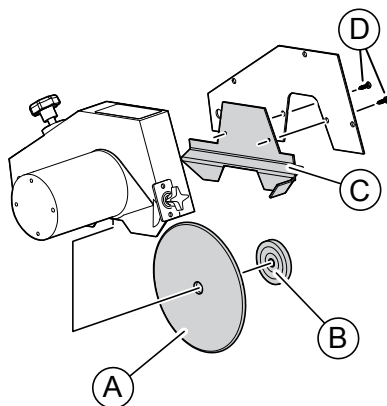

5. Remove the wheel attachment nut from the hub.

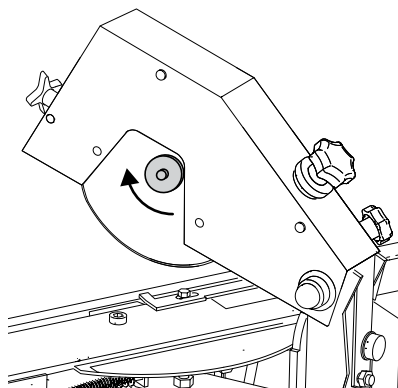

- Next, insert the appropriate wheel onto the hub, and using moderate pressure with your hands, secure the wheel attachment nut to hold the wheel in place.

⚠ WARNING Over-tightening the wheel can cause it to break.

- Finally, reposition the shield and secure it in place with the retaining screw.

⚠ WARNING Never start the grinder without the wheel guards in place.

- Before using the grinder, you'll need to check to ensure the wheel is properly installed.
- With the power off, gently spin the grinding wheel and check for wheel wobble.
- Conduct a final check for proper assembly by turning on the main power and switching on the wheel power switch while standing to the side. Look for vibrations due to wheel oscillation or other interference.

⚠ WARNING Always keep bystanders at a safe distance from a grinder while in operation.

⚠ CAUTION The grind wheel is designed to rotate away from the operator. This safety feature reduces the likelihood of sharp pieces of shrapnel striking the operator should the wheel fracture or break during the grinding process. Therefore, do not stand behind the grinder when it is operating.

Note: To get the best performance from your grinder, ensure the grinding wheel is centered over the vise. Refer to this user manual or the provided video for specific instructions.

4.8 Test the machine before first use

- Make sure that all packing materials are removed.

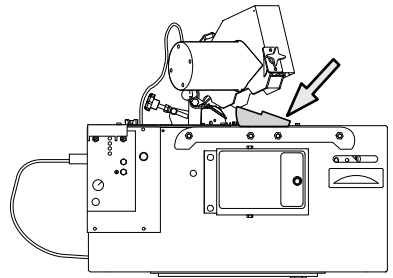
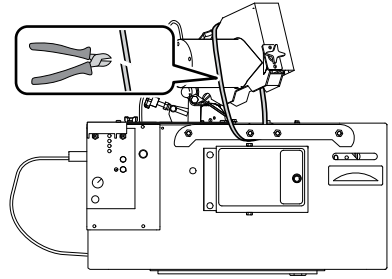

- Make sure that the air hoses and wires are correctly connected.
- Make sure that the machine is securely fastened to the stand.
- Make sure that the machine is on a level surface; if the machine wobbles, or if the surface is not level, attach the stand to the floor with screws.
- Perform a sharpening test on the machine to ensure it functions correctly. See section 7.2, "Sharpening test"

5 Operation



5.1 Safety during operation

⚠ WARNING Before you install, operate, or perform maintenance on the machine, you must read the operators manual. Obey the instructions in this manual to prevent injuries or damage to the equipment.

⚠ WARNING Always wear safety gloves, protective glasses, and any other personal protective equipment suitable for your task.

⚠ WARNING To prevent mistakes when chains are sharpened, it is very important to understand how the grinding machine works. Read the instructions carefully before the machine is used.

5.2 Preparing for operation

Note: For a video demonstration of how to install and operate the machine, go to OregonProducts.com.

5.2.1 Preparing the grinding wheel

⚠ WARNING Before a chain is sharpened, make sure that the grinding wheel is not cracked, does not vibrate, or wobble. Perform a "ring test"; see section 4.7, "Installing the grinding wheel". If the grinding wheel is damaged, it must be replaced immediately; see section 6.3, "Changing the grinding wheel and fitting the grinding wheel guard"

If abnormal vibrations occur during operation, immediately stop the machine and check the condition of the grinding wheel. Make sure all the switches are turned off before turning the power back on.

Note: Before each chain is sharpened, make sure the grinding wheel edges match the shape of the chain type.

The condition, type and profile of the grinding wheel is essential for the machine's accurate operation. The instructions that follow contain information on how to make sure that the grinding wheel is in good condition and has the correct profile.

1. Press the power button to turn on the machine.

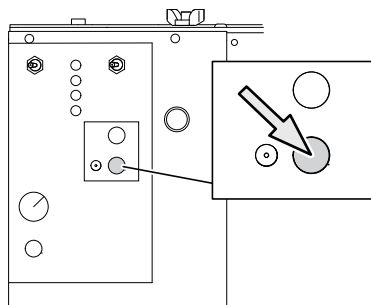

2. Set the grinding speed knob to medium speed.

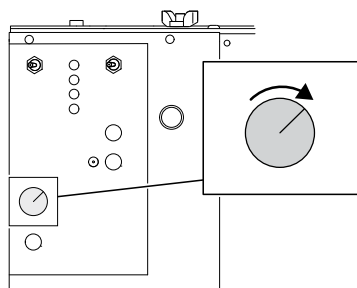

3. Set the grinding wheel switch to ON.

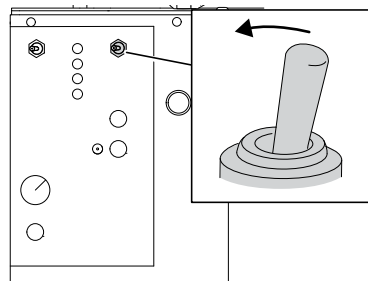

4. Make sure that the grinding wheel does not vibrate or wobble. If the grinding wheel is damaged, it must be replaced immediately; see section 6.3, "Changing the grinding wheel and fitting the grinding wheel guard"

5. Make sure the grinding wheel edges match the shape of the chain type.
 - For ceramic grinding wheels: Use the profile stone (included in delivery) to shape the edges on the grinding wheel. Use a light-sweeping action to shape the edges of the wheel. Use the provided template to verify proper radius shape for the specific grinding wheel being used

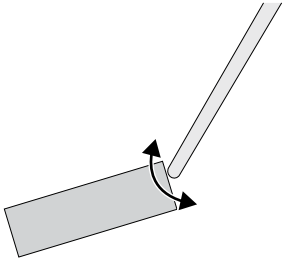

6. Set the grinding wheel switch to OFF.

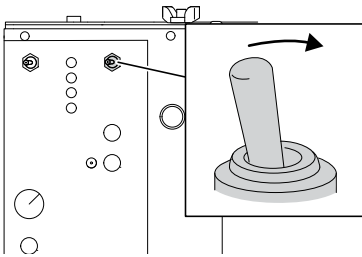

7. Use the profile template to verify that the grinding wheel has the same profile as the type of chain to be sharpened.

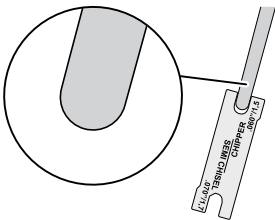

8. Repeat steps 5-7 until the grinding wheel profile is the same as the selected profile on the profile template.

5.2.2 Setting the head-tilt angle

Note: Read the specifications from the chain manufacturer to find out the recommended head-tilt angle for your chain.

1. Use an adjustable wrench to loosen the head-tilt angle nut located on the back of the machine.

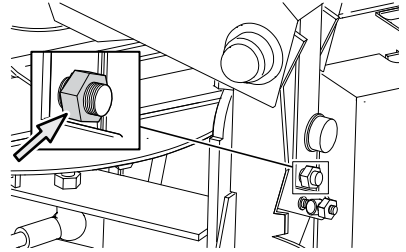

2. Turn the grinding head to set the desired head-tilt angle (50-90°) on the head-tilt angle scale. The default head-tilt angle is 60°.

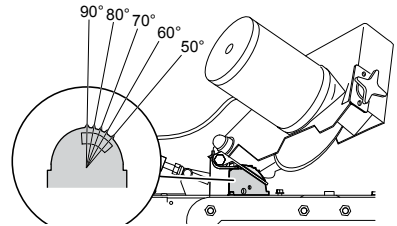

3. Tighten the head-tilt angle nut.

5.2.3 Setting the top-plate angle

Note: Read the specifications from the chain manufacturer to find out the recommended top-plate angle for your chain.

1. Use the hex key (provided with the machine) to loosen the top-plate angle screw up to three turns.

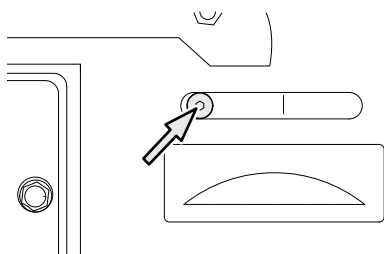

2. Turn the grinding head to set the desired top-plate angle (0-35°) on the top-plate angle scale. The default top-plate angle is 30°.

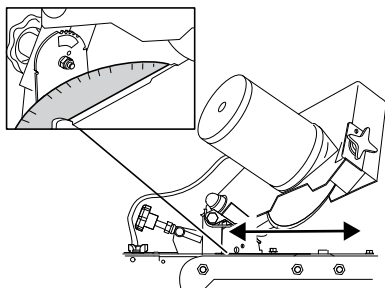

3. Tighten the top-plate angle screw.
4. Press the grinding head positioning button to move the grinding head in both directions and make sure that the top-plate angles are the same.

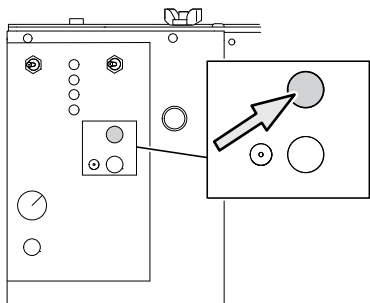

5. If the top-plate angles are not the same (for example 26° in the right direction and 30° in the left direction), adjust the nuts (A) a 1/2-turn at the time.

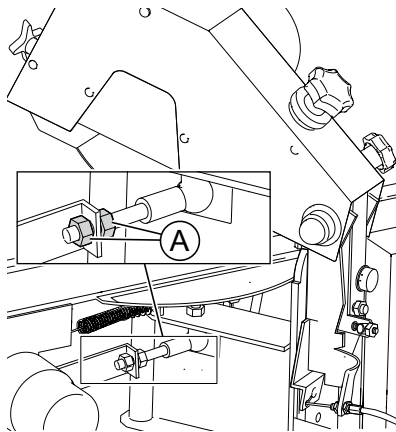

6. Repeat steps 2-5 until the top-plate angles are the same in both directions.

5.2.4 Inserting the chain

1. Check the chain for double-links (2 left cutters or 2 right cutters) or joint-links, and make sure that the chain is not damaged. Mark double-links or joint-links to make it easier to see them when the chain is sharpened.
2. Attach the stop clamp on a tie-strap between a double-link or a joint-link.

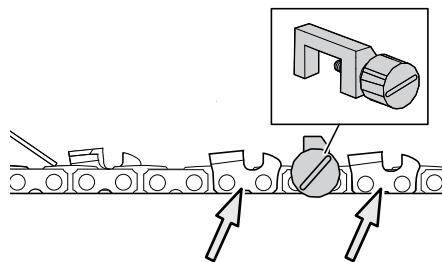

- Place the chain, with the cutter to the left of the depth gauge, into the groove on the chain vise.

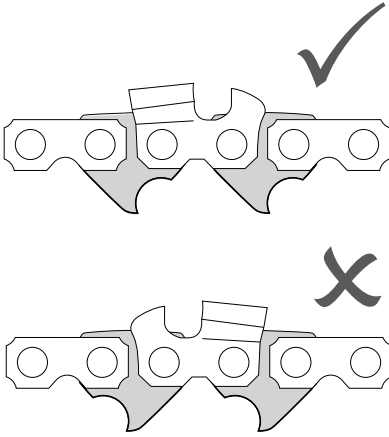

- Pull the chain around by hand to make sure that it runs freely in the chain vise.

⚠ CAUTION Always wear gloves and protective eyewear while you work and operate your grinder.

- Loosen the locking handle and move the tensioner upward or downward to make enough room to position the chain.

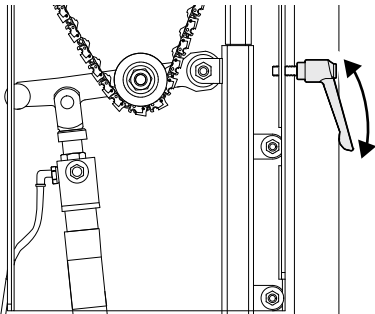

- Lift the tensioner arm (there is a quick release function) and place the chain below the tensioner roll.

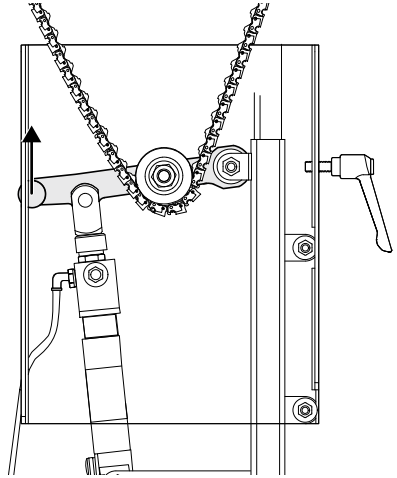

- Lower the tensioner arm to its bottom position.

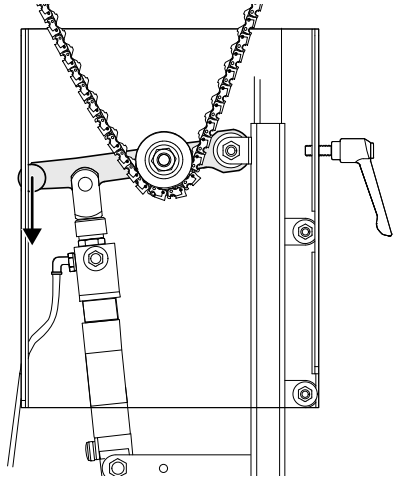

8. Move the tensioner downward until the chain is tightly secured in its position. There should be a gap of about 1/2" (12.7 mm) between the pneumatic-piston nut and pneumatic piston where the piston should be visible.

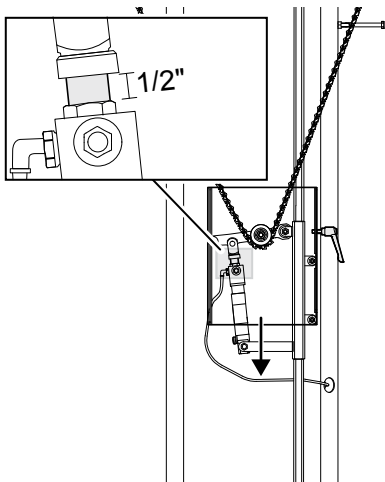

9. Tighten the locking handle to secure the chain.

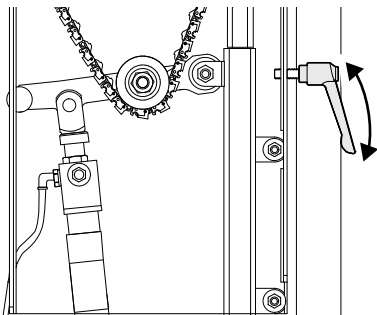

10. Gently press the chain with your hand to test the tension. The chain should not slacken.

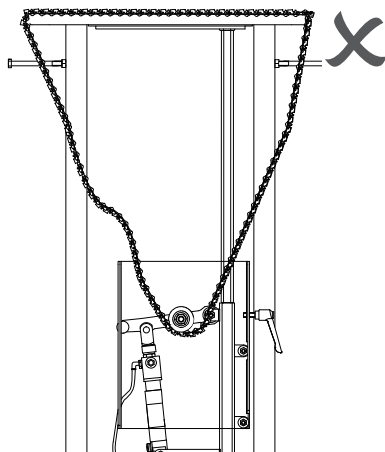
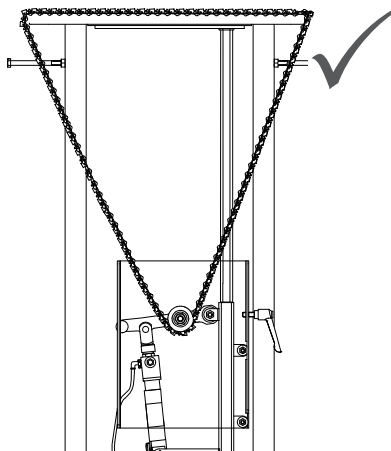

11. If the chain tension is too loose, repeat the procedure.

Note: If you need to fit longer chains, you can order a telescopic chain extension kit. See section 8, "Accessories and Spare Parts"

5.2.5 Making the grinding settings

⚠ CAUTION! Do not change the pitch setting. The default setting is for 3/4" chains. If there is a problem with the pitch, see "7.3 Changing the pitch" on page 39 for instructions on how to change the pitch setting.

1. Press the power button to turn on the machine.

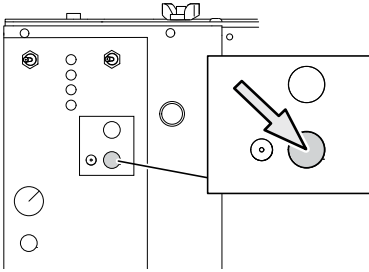

2. Press the grinding head positioning button to move the grinding head so that it is tilted in the correct start position for the next cutting link to be ground.

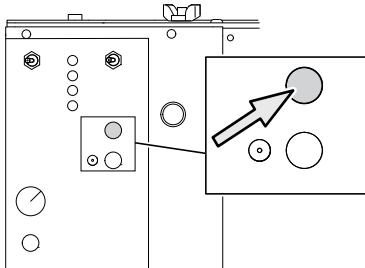

3. Lift the grinding head to its uppermost position.
4. Set the chain pusher switch to ON. The chain pusher arm now advances the chain forward.

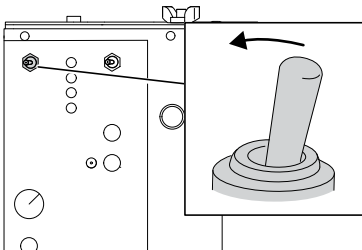

5. Visually make sure that the chain pusher stops its movement exactly above the rivet behind the cutter, as illustrated in the image below.

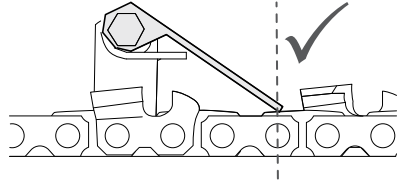

6. Set the chain pusher switch to OFF when the grinding head is in its uppermost position and the chain lock is not engaged.

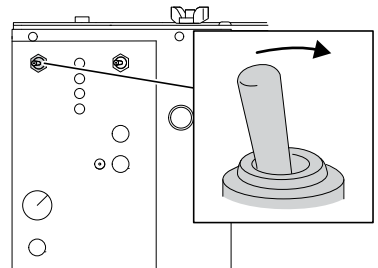

7. Repeat steps 5-8 until the chain pusher stops in the correct position.
8. Turn the grinding speed knob to set the desired speed for the machine.

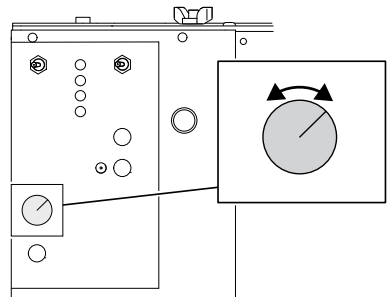

⚠ IMPORTANT If the metal of a cutter turns blue during grinding, the speed is set too high and the metal is overheated. This can cause the metal in the cutter to lose its properties. Replace the damaged cutter or re-sharpen the chain.

9. Fold the grinding head down to its grinding position.
10. The grinding depth for gullets is recommended by the chain manufacturer. To set it, turn the grinding depth knob located on the back of the grinding head:

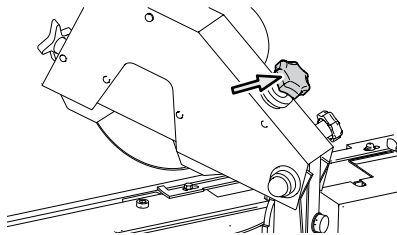

- clockwise, to grind shallower into the gullet, or
- counterclockwise, to grind deeper into the gullet.

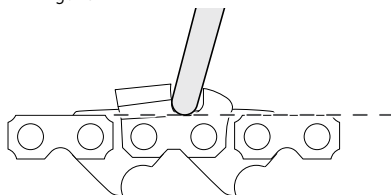

11. Set the cutter top plate to equal lengths. If the right (outer) and left (inner) cutters are not sharpened to equal lengths, follow these steps:
 - Do a sharpening test on a test chain according to the instructions in section 7.2, "Sharpening test"
 - Make sure that the right and left cutting teeth are sharpened to equal lengths. Use the template provided with the machine to measure. If they are not equally long, turn the equal cutting teeth knob:
 - clockwise to decrease the length of the left cutter and increase the length of the right cutter, or
 - counterclockwise to increase the length of the left cutter and decrease the length of the right cutter.
 - Repeat the sharpening test until the cutter top plates are sharpened to equal lengths.

12. The diameter of the grinding wheel decreases when it is used. To maintain the grinding proportions, the grinding wheel position must be changed when the grinding wheel has been worn.

The grinding wheel centering knob is used to center the grinding wheel over the chain. The gullets should have equal depth on the left and right cutting links.

- Sharpen a few links and then visually inspect the result. If the grinding depth is not equal on the gullets of the right and left cutting links, continue to the next step.
- Turn the grinding wheel centering knob to move the grinding motor and the wheel up or down. Set the arrow on the scale to point to the number that corresponds to the wheel diameter, as displayed below. These scale numbers are approximate and are only for general guidance. Observe if the grinding depth of right and left gullets are equal for final adjustment.

Grinding wheel diameter:	Scale:
5.9" (150 mm) (new grinding wheels)	1-3
5.5" (140 mm)	3-5
5.1" (130 mm)	4-6

- Repeat steps 1-2 until the grinding depth is equal.
13. To set the approximate grinding length, turn the chain pusher adjustment knob:

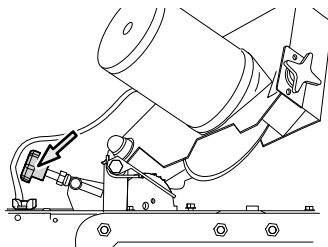

- clockwise, to grind more, resulting in a shorter cutter top plate, or

- counterclockwise, to grind less, resulting in a longer cutter top plate.

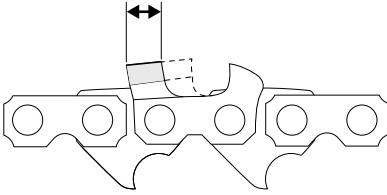

14. Set the chain pusher switch to ON. The chain pusher arm will push the chain forward

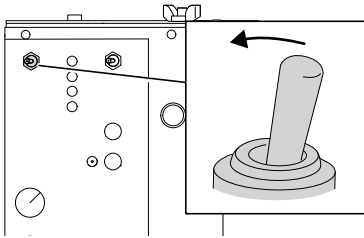

15. Monitor the grinding wheel movements, and check if the chain is sharpened.
16. If required: turn the grinding depth knob, located on the back of the grinding head, to make minor adjustments for the grinding depth.

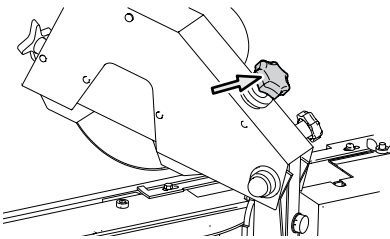

17. If required: turn the chain pusher adjustment to make minor adjustments for the grinding length.

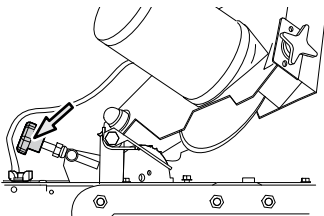

18. Set the chain pusher switch to OFF when the grinding head is in its uppermost position and the chain lock is not engaged.

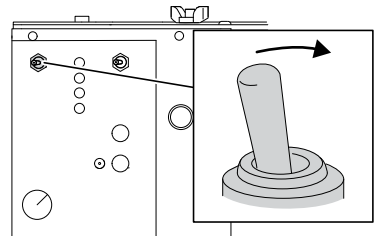

⚠ IMPORTANT If the chain has double-links, pull the chain back so that the grinding starts on the second double-link. If the chain has a joint with an irregular cutter sequence, start grinding behind it, to the left of the stop clamp.

5.3 Operating the machine

⚠ WARNING Always wear safety gloves, protective glasses, and any other personal protective equipment suitable for your task.

⚠ WARNING Stop the machine immediately if it does not work correctly!

Note: For a video demonstration of how to install and operate the machine, go to OregonProducts.com.

Note: Discard the chain when the longest part of the cutting tooth is less than half the original length of the cutting tooth, or if you find cracks or burrs in the chain.

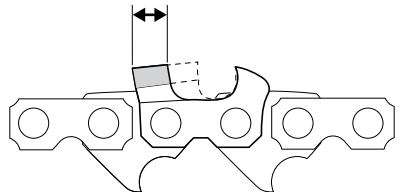

1. Set the grinding wheel switch to ON to start grinding motor.

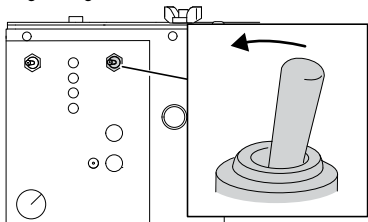

2. Set the chain pusher switch to ON to start the feeding of the chain and the movement of the grinding head. The sharpening will start after this.

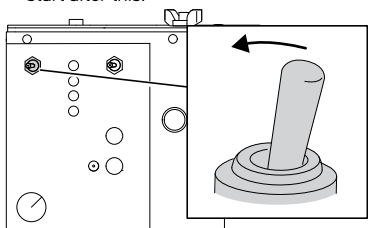

3. Wait until the machine has sharpened all the links until the stopper. When the stopping clamp is reached, the chain feeding and the grinding stops.
4. Lift the grinding head to its most upright position.
5. Set the grinding wheel switch to OFF.

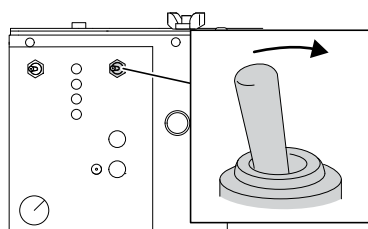

6. Set the chain pusher switch to OFF.

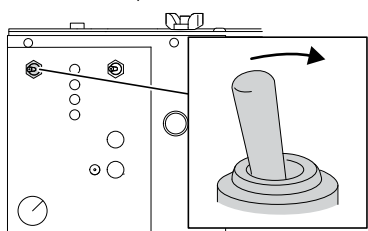

7. Lift the tensioner arm (quick release function) and remove the chain.

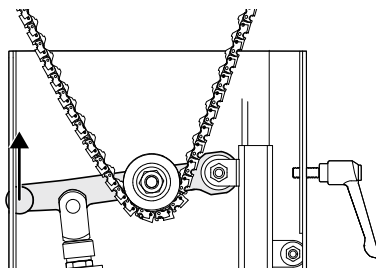

8. To turn off the power to the machine, press the emergency stop button.

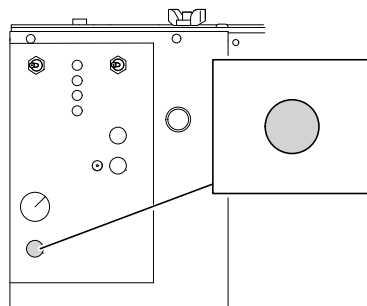

▲ IMPORTANT Grinding dust can interfere with the machine's operation. Clean the machine daily to remove all of the grinding dust. Use a vacuum cleaner, brush, or similar to clean the machine.

5.4 Depth gauge grinding

1. Change the grinding wheel to OR600-38 See section 4.7, "Installing the grinding wheel"
2. Shape the edges of the grinding wheel to make sure that the shape is correct. See section 5.2.1, "Preparing the grinding wheel"

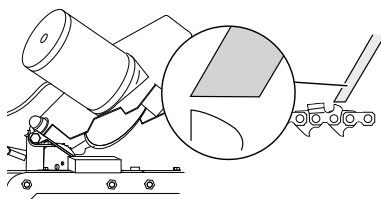

3. Set the top plate angle to 0°. (See 5.2.3 Setting the top-plate angle)

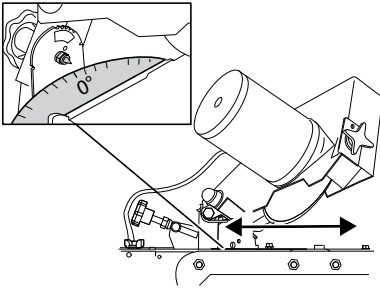

4. Set the head tilt angle to 60°. (See 5.2.2 "Setting the head tilt angle.")

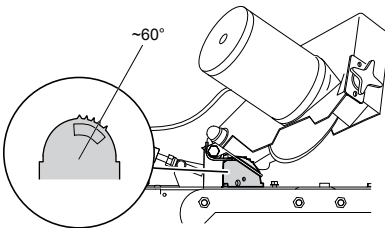

5. Remove the screw holding the chain pusher. Remove the chain pusher. Attach the shorter change pusher. Attach and fasten the screw.

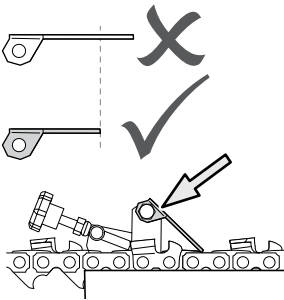

6. Change the grinding setting for the height of the depth gauges.

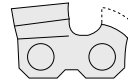

Set the depth gauge height:

- Do a sharpening test on a test chain, according to the instructions in section "7.2 Sharpening test" on page 39.
 - Use an Oregon flat file to set the height of the depth gauge. Once you have set the depth gauge, refer back to the template to make sure it meets the correct specifications.
 - Use the set depth gauge to adjust the position of the machine to set up the remaining depth gauges. Turn the depth gauge height knob:
 - clockwise to set the first depth gauge by hand using the flat file and depth gauge tool.
 - clockwise to increase the height of the depth gauge (and therefore grind less of it), or
 - counterclockwise to decrease the height of the depth gauge (and therefore grind more of it).
 - Repeat the sharpening test until the height of the depth gauges is correct. Use the template provided with the machine and refer to the top-plate angle chart to determine the correct height.
7. Adjust the feed so that the grinding wheel touches the depth gauge.

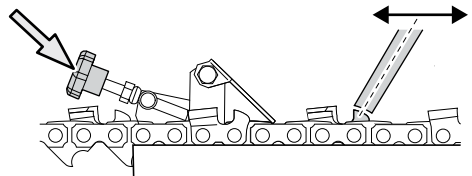

8. Make the grinding settings according to the manufacturer's recommendations.

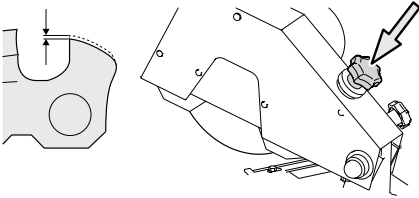

9. Attach the stop clamp on a tie-strap between a double-link or a joint-link.

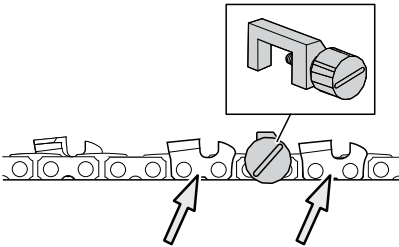

10. Begin grinding to the left of the stop clamp.

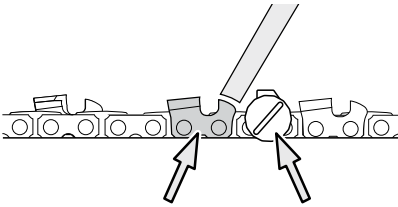

6 Maintenance and Service

6.1 Safety during maintenance

- ⚠ WARNING** Make sure that the power is turned off before you install, operate, or perform maintenance on the machine.
- ⚠ WARNING** Before you install, operate, or perform maintenance on the machine, you must read the safety information in this manual. Obey the instructions in this manual to prevent injuries or damage to the equipment.
- ⚠ WARNING** Always wear safety gloves, protective glasses, and any other personal protective equipment suitable for your task.
- ⚠ WARNING** The user must only perform maintenance that is described in this manual. Only approved and trained service technicians can service the machine.

6.2 Frequency of maintenance

Maintenance Step	When	Description
Cleaning	Daily	Clean the machine daily to remove grinding dust. Use a vacuum cleaner or brush to clean the machine
Change grinding wheels	If worn or damaged	See section 6.3, "Changing the grinding wheel and fitting the grinding wheel guard"
Center the grinding wheel	When worn or if the chain has a different width than the previous	See step 14 of section 5.2.5, "Making the grinding settings"
Check and adjust the wire	Once every 3 months, depending on usage	See section 6.5, "Checking and adjusting the wire"
Fasten the chain vise	If the chain is loose during operation	See section 6.4, "Fastening the chain vise"

6.3 Changing the grinding wheel and fitting the grinding wheel guard

⚠ WARNING Before a chain is sharpened, make sure that the grinding wheel is not cracked and does not vibrate or wobble. There is a simple test (called the "ring test") that you can do to check for damage (see step 1 of section 5.2.1, "Preparing the grinding wheel").

IF THE GRINDING WHEEL IS DAMAGED IT MUST BE REPLACED IMMEDIATELY. If abnormal vibrations occur during operation, stop the machine immediately and check the condition of the grinding wheel.

The machine comes with 2 grinding wheels of different sizes. To order more grinding wheels, see section 8, "Accessories and Spare Parts"

1. Press the emergency stop button to turn the power off.

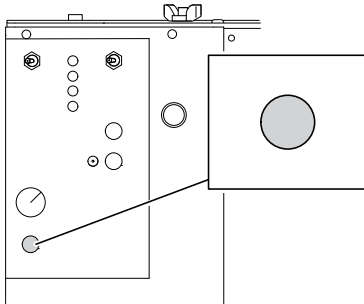

2. Lift the grinding head to its most upright position.
3. If the grinding wheel guard is already attached, loosen the 2 screws (D) and remove the guard (C).

4. Hold the grinding wheel and loosen the nut (B).

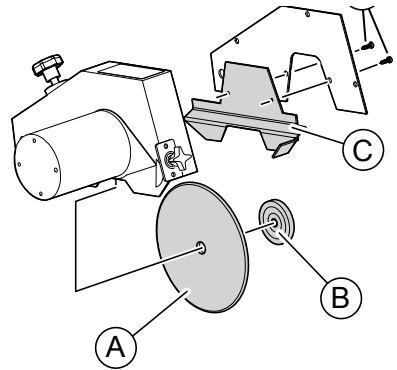

5. Remove the grinding wheel (A) from the grinding wheel axis and discard it in accordance with local, state, and national laws and regulations.
6. Place a new grinding wheel (A) on the grinding wheel axis.
7. Tighten the nut (B) by hand to secure the grinding wheel in its position. Do not over-tighten the nut.
8. Place the grinding wheel guard (C) in its position and fasten the 2 screws (D).
9. Center the grinding wheel following the instructions on step 14 of section 5.2.5, "Making the grinding settings"

⚠ WARNING Replace guards and keep in good working order. Never start a grinder without the wheel guards in place.

6.4 Fastening the chain vise

The chain vise needs to be fastened if the chain is not fixed during sharpening.

1. Insert a 0.070" (1.8 mm) to 0.078" (2.0 mm) feeler gauge into the groove of the chain vise to measure the groove width.

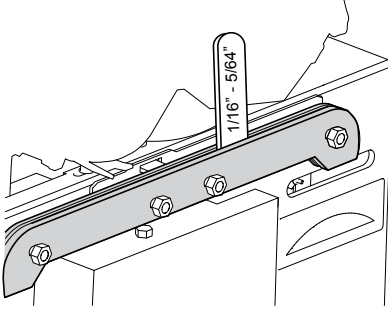

2. Turn the nut (A) in 1-1.5 turns clockwise, until the groove in the chain vise is 0.070" (1.8 mm) to 0.078" (2.0 mm) wide.

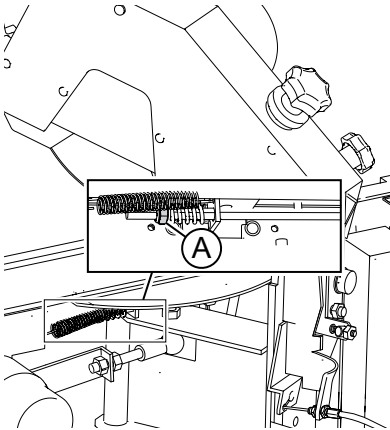

3. Do a sharpening test and make sure that the chain remains in its position during the test. See section 7.2, "Sharpening test"
4. If required: Repeat steps 1-3 until the chain is fixed during sharpening.

6.5 Checking and adjusting the wire

Note: If the wire is not correctly set, the grinding machine will not operate correctly. The manufacturer initially sets the wire, but it will become worn during normal machine operations. Always make sure that the wire is set correctly. If necessary, adjust or replace the wire.

1. Press the power button to turn on the machine.

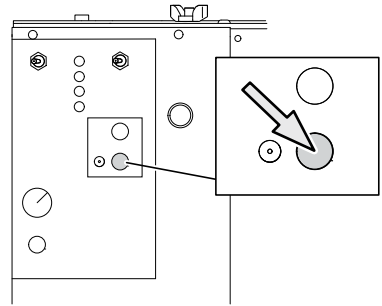

2. Set the grinding speed knob to high speed. See section 3.6.1, "Grinding speed knob"

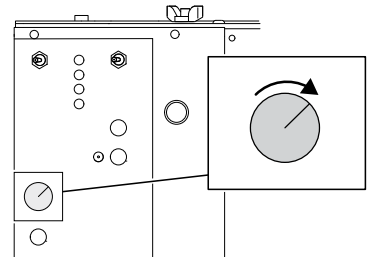

3. Press the grinding head positioning button to turn the grinding head to the left.

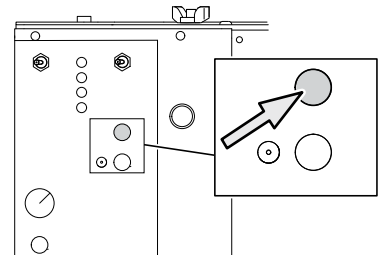

- Set the top-plate angle to 30°. See section 3, "Tighten the head-tilt angle nut." for instructions.

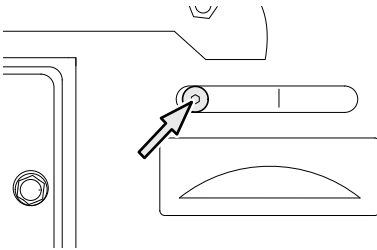

- Set the chain pusher switch to ON.

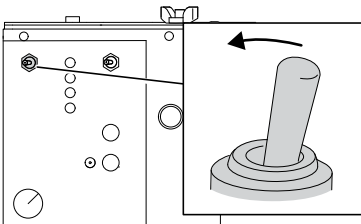

- Place a 0.019" (0.05 mm) feeler gauge (B) between the lifting arm (C) and the flange (A) and make sure that the lifting arm completely meets the flange for about 1.5 seconds before it lifts again.

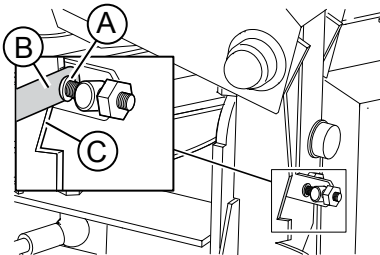

- If the test is successful, the wire does not need to be adjusted. The test is finished.
- If the lifting arm and flange do not completely meet or do not meet long enough, perform the next steps.
- If the wire is damaged or worn, it must be replaced; see section 8, "Accessories and Spare Parts" When it has been replaced, repeat steps 1-8.

- Set the chain pusher switch to OFF.

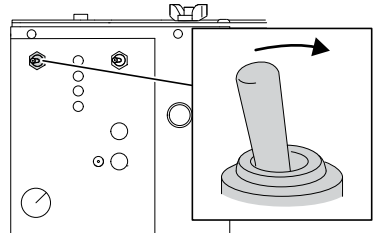

- To set the wire so that the lifting arm meets the flange:
 - for a shorter time: turn the 2 nuts (D) in the direction towards the machine.
 - for a longer time: turn the 2 nuts (D) in the direction from the machine.

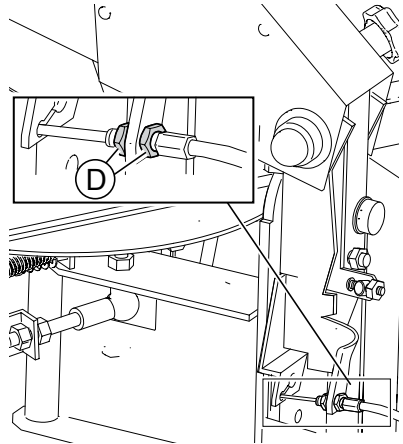

- Repeat steps 5-8 until the test is successful.

6.6 Service

⚠ WARNING The user must only perform maintenance that is described in this manual. Only approved and trained service technicians can service the machine.

Note: Keep the delivery crates and packing material. Pack the machine carefully if it is moved or sent for service. The crates and packing material will minimize the risk of damage during transportation.

7 Troubleshooting

7.1 Troubleshooting procedure

1. Make sure that the machine has sufficient power.
2. Read section 7.4, "Issues" and section 7.5, "Troubleshooting indicators" to find a description of the issue.
3. Perform the recommended corrective procedures.
4. Perform a sharpening test, see instruction in section 7.2, "Sharpening test."
5. If the problem persists after corrective procedures, contact your regional sales representative to reach your service team.

7.2 Sharpening test

⚠ WARNING Stop the machine immediately if it does not work correctly!

Perform a sharpening test when:

- the machine is new,
- to learn how to use the machine, or
- if the chain is not sharpened as expected.

Recommendation: Use an old chain for the test.

1. Insert a test chain into the machine and sharpen it according to the instructions in section 5, "Operation."
2. Test the functions of the machine and study its motions.
3. Make sure that:
 - the right (outer) and left (inner) cutters are sharpened to even lengths. Use a slide-gauge to measure. If they are uneven, see steps 15 and 16 of section 5.2.5, "Making the grinding settings."
 - the grinding depth on the chain is deep enough. If the grinding wheel is worn, it needs to be adjusted, see step 14 of section 5.2.5, "Making the grinding settings." If it needs to be changed, see section 6.3, "Changing the grinding wheel and fitting the grinding wheel guard."
4. Repeat the sharpening test until you see satisfactory test results, and the machine is running trouble-free.
5. Remove the test chain.

7.3 Changing the pitch

1. Lift the grinding head to its uppermost position.
2. Loosen the chain pitch wing-nut and move it to the correct pitch position. Tighten it again.

Note: Adjusting the pitch is not the same thing as adjusting the cutting tooth length.

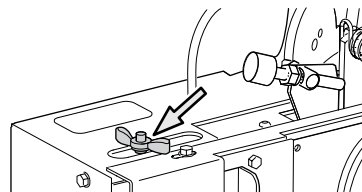

7.4 Issues

Issues	Possible cause	Corrective procedure
The grinding head "falls" without slowing down before it touches the cutter.	The wire is worn and needs to be adjusted.	See section 6.5, "Checking and adjusting the wire"
The lengths of the right and left cutters are not the same.	The equal cutting teeth knob is incorrectly set.	See step 13 of section 5.2.5, "Making the grinding settings".
One of the troubleshooting indicator LEDs on the control panel is lit up.	There is an issue with one of the motors. An alarm is triggered and must be corrected.	See section 7.5, "Troubleshooting indicators".
The chain is not fixed during sharpening.	The chain vise is loose.	See section 6.4, "Fastening the chain vise".
	The air pressure is too low.	Check and adjust the air pressure.
The wrong cutter is sharpened.	The chain was in the incorrect position when the machine was started.	Find the cutter to be sharpened and make sure that it is in the correct position before the machine is operated. See section 5.2.5, "Making the grinding settings".
The top-plate angles are not the same (e.g. 35° in one direction and 25° in the other) when the grinding head turns in the 2 different directions.	The M6 nuts needs to be adjusted.	See section 3, "Tighten the head-tilt angle nut".
Wrong parts of the cutters are sharpened.	The pitch adjustment wing is not in the correct position for the type of chain used.	See section 5.2.5, "Making the grinding settings".
	A cutter was caught on the chain pusher because the chain pusher is worn out and the material is uneven.	Loosen the screw that holds the chain pusher in its position. Discard the chain pusher in accordance with local, state, and national laws and regulations. Attach a new chain pusher and fasten the screw.
		File the chain pusher with a rasp until the material is even.
The cutters are not correctly sharpened.	Incorrect settings are used.	See section 5.2.5, "Making the grinding settings".
The top-plate angle is too aggressive.	The top-plate angle setting is incorrect.	See section 5.2.5, "Making the grinding settings".
The metal of a cutter turns blue during grinding, which is an indication of damaged or weakened metal.	The grinding speed is set too high and the metal is overheated.	Replace the damaged cutter or discard the chain. Lower the speed on the grinding speed knob, see section 3.6.1, "Grinding speed knob".
The depth of the gullets on the left and right cutters are unevenly sharpened.	The grinding wheel is not centered between the cutters.	See the instructions in step 14 of section 5.2.5, "Make the grinding settings".

7.5 Troubleshooting indicators

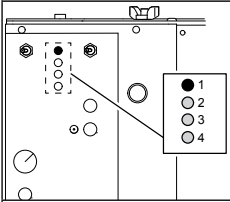
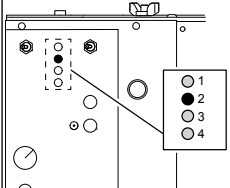
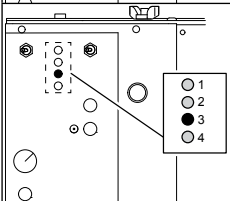
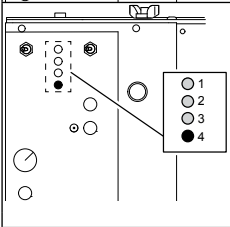
Pos	Description	Possible cause	Corrective action
	The chain pusher motor indicator shows a red light and the chain pusher motor is slow or has stopped.	The chain pusher motor or gear is broken.	Contact your regional sales representative to reach your service team.
	The grinding motor indicator shows a red light.	Shows that the grinding motor is broken.	Contact your regional sales representative to reach your service team.
	The chain pusher motor pulse indicator shows a flashing red light.	Shows the speed of the pulsing motion of the grinding head.	This is not an error indication. The chain pusher motor indicator is purely informative.
	The turning motor indicator shows a red light.	Shows that the turning motor or gear is broken, malfunctioning or that the power to the turning motor is broken.	Contact your regional sales representative to reach your service team.

8 Accessories and Spare Parts

8.1 Ordering information

Contact your local Oregon distributor or dealer to order parts and accessories. Distributor and dealer locators can be found at OregonProducts.com

8.2 List of accessories

Accessory	Description	Order Number
Profile stone	Stone for profiling ceramic grinding wheels.	590682
Profile template	Template show how to profile the grinding wheel for different chain types.	590683
Air tension extension	Shorter chains – smaller than 40 drive links – require this extension to properly engage the tensioning system.	591152
Telescopic chain extension kit	For extra long (.404 & 3/4") harvester chains, our telescopic extension is an ideal choice. It accommodates up to 12 ft. chain loops.	590247
Battery cable	Battery cable for using the grinder with a 12V battery source, without the AC/DC converter.	590679
Chain weight	Used to tension chain when machine is not mounted on the stand with air tensioner.	590246
Grinding wheels	Dimensions (OD x W x ID)	Order Number
Ceramic grinding wheels	150 mm x 7.9 mm x 16 mm (5 7/8" x 5/16" x 5/8")	OR600-516
	150 mm x 10 mm 16 mm (5 7/8" x 3/8" x 5/8")	OR600-38
CBN grinding wheels	145 mm x 7.9 mm x 16 mm (5-3/4" x 5/16" x 5/8")	OR534-516-CBN

8.3 Spare parts

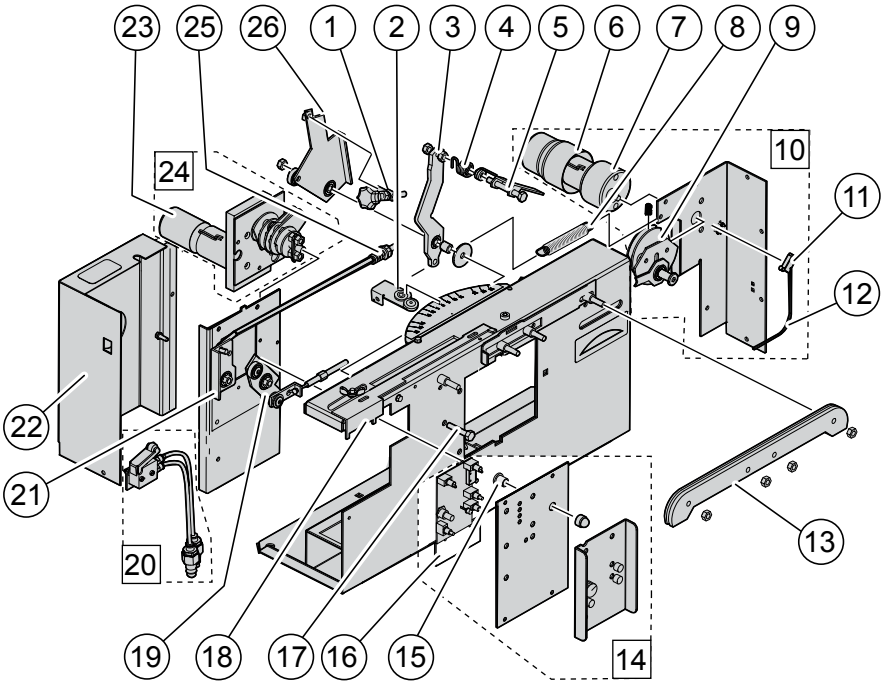

Pos	Spare Part	Order Number
1	Adjuster complete	590713
2	Chain lock	595283
3	Holder	590701
4	Spring	590704
5	Chain pusher	590703
6	Motor cover	590684
7	Turning motor	590685
8	Tension spring	590702
9	Cam curve assembly	590856
10	Turning motor assembly	590819
11	Micro switch	590688
12	Wiring harness	590820
13	Chain vise	590846
14	Control panel assembly	590712
15	PDE bearing	590691
16	Control unit (PCB)	590717
17	Bolt M6 x 30	590694
18	Stop arm	595282
19	Wire lifter assembly	595284
20	Pneumatic valve assembly	590859
21	Lock axis assembly	590697
22	Motor housing	595285
23	Motor cover	590858
24	Chain pusher motor assembly	595287
25	Compression spring	590832
26	Chain pusher plate	595287

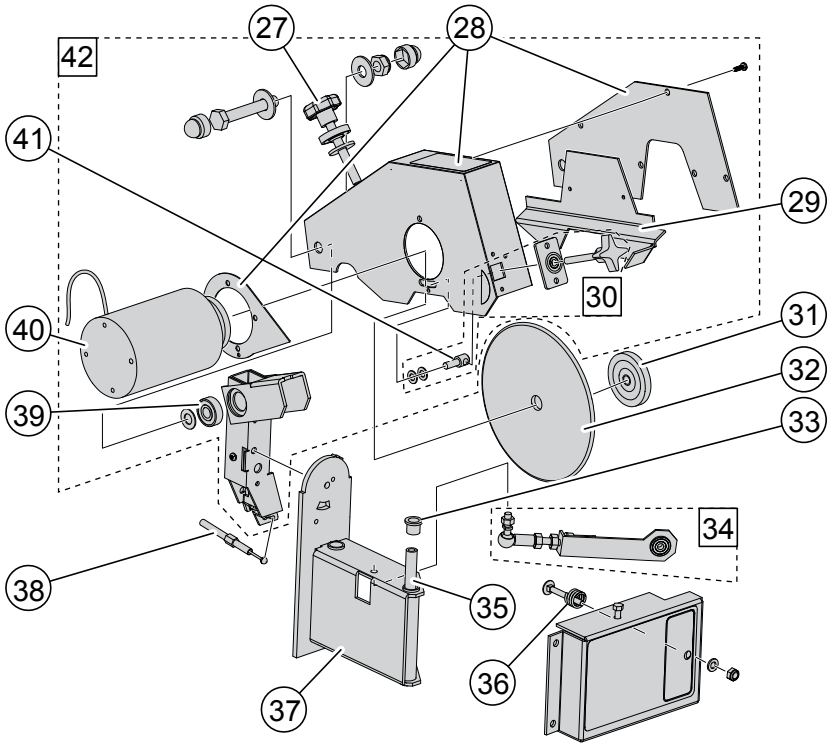



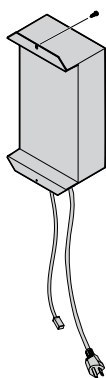

Pos	Spare Part	Order Number
27	Adjuster assembly	590720
28	Grinding head cover	590839
29	Grinding wheel guard	590845
30	Grinding wheel centering knob assembly	590840
31	Grinding wheel nut	590841
32	Grinding wheel, see section 8.2, "List of accessories" for ordering information	
33	PDE bearing	590813
34	Turning arm assembly	590842
35	Axis	590843
36	Center spring	590848
37	Degree beam	595289
38	Wire	590817
39	Ball bearing 6000ZZ	590816
40	Grinding motor	590721
41	Adjusting nut	590855
42	Grinding head assembly	595288

8.4 Converter



Pos	Spare Part	Order Number
	Converter	590528

9 Instrumental Measurements

		X	A	B	C
					
Code	Oregon Chain Part Number	Wheel Width	Top-Plate Angle	Head-Tilt Angle	Depth Gauge
	11H	5/16"	30°	50°	.070" 1.7 mm
	11BC	5/16"	35°	60°	.060" 1.5 mm

- A Measure the gauge depth using the suitable shape.

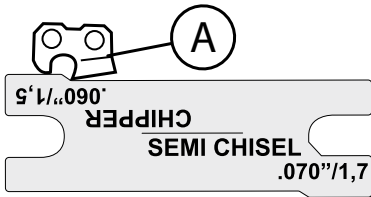

10 Warranty and Service

Limited Warranty

At Oregon, our goal is help you get the job done right with outstanding products that perform to your full satisfaction. Oregon | Blount Inc. warrants its products to be free from defects in materials and workmanship for two (2) years from the original date of purchase. If for any reason, you are not satisfied with our products, please let us know. Our contact information is listed below.

LIABILITY UNDER THIS WARRANTY IS LIMITED TO REPLACEMENT PARTS, AT THE OPTION OF YOUR OREGON DISTRIBUTOR AND OREGON. PLEASE CONTACT YOUR OREGON DISTRIBUTOR OR US DIRECTLY. OREGON PRODUCTS ARE NOT WARRANTED AGAINST NORMAL WEAR AND TEAR, USER ABUSE, IMPROPER MAINTENANCE OR IMPROPER REPAIR.

REPLACEMENT OF DEFECTIVE PRODUCT IS THE EXCLUSIVE REMEDY UNDER THIS WARRANTY AND ANY APPLICABLE IMPLIED WARRANTY. THE REPLACEMENT WILL BE UNDERTAKEN AS SOON AS REASONABLY POSSIBLE AFTER RECEIPT OF THE DEFECTIVE PRODUCT. TO THE EXTENT PERMITTED BY LAW, ANY IMPLIED WARRANTY OF MERCHANTABILITY OR FITNESS FOR A PARTICULAR PURPOSE APPLICABLE TO THIS PRODUCT IS LIMITED TO THE DURATION AND SCOPE OF THIS EXPRESS WARRANTY. OREGON SHALL NOT BE LIABLE FOR ANY CONSEQUENTIAL OR INCIDENTAL DAMAGES. SOME STATES DO NOT ALLOW LIMITATIONS ON HOW LONG AN IMPLIED WARRANTY LASTS OR DO NOT ALLOW THE EXCLUSION OF CONSEQUENTIAL DAMAGES, SO THE ABOVE LIMITATION OR EXCLUSION MAY NOT APPLY TO YOU. THIS WARRANTY GIVES THE ORIGINAL OWNER SPECIFIC LEGAL RIGHTS, AND YOU MAY ALSO HAVE OTHER RIGHTS WHICH VARY FROM STATE TO STATE.

You Can Reach Us Several Ways

We're here to take your calls between 7:30 a.m. and 4:00 p.m. (Pacific Time) Monday through Friday. Our phone number is 800-223-5168. Or, write to us at: Technical Services Department, Oregon | Blount, Inc., P.O. Box 22127, Portland, Oregon 97269-2127. You can also visit our website at OregonProducts.com. Use the "Technical Information" or "Technical Services" links.

The warranty validity is acknowledged in the country of sale. Claims under warranty will only be accepted if they are backed up by the copy of the purchase document (bill or receipt). The guarantee becomes void if:

- The machine has been tampered with;
- The machine has not been used according to this manual;
- Non-original parts, machines or grinding wheels have been fitted on the grinder or other parts that are not authorized by the manufacturer;
- The machine has been powered at a voltage or frequency different from that written in the rating nameplate.

Oregon products may be protected by one or more patent(s): OregonProducts.com/patents
Oregon® is a trademark of Blount, Inc. All other marks are property of their respective owners.



Blount, Inc.
4909 SE International Way
Portland, Oregon 97222 USA

OregonProducts.com